

REVISIONS				
ZONE	REV.	DESCRIPTION	DATE	APPROVED
	A0.0	Original Release	9/23/2016	JRK
C4	A1.0	Added Notes 2, 3 and 4	5/10/2021	JRK

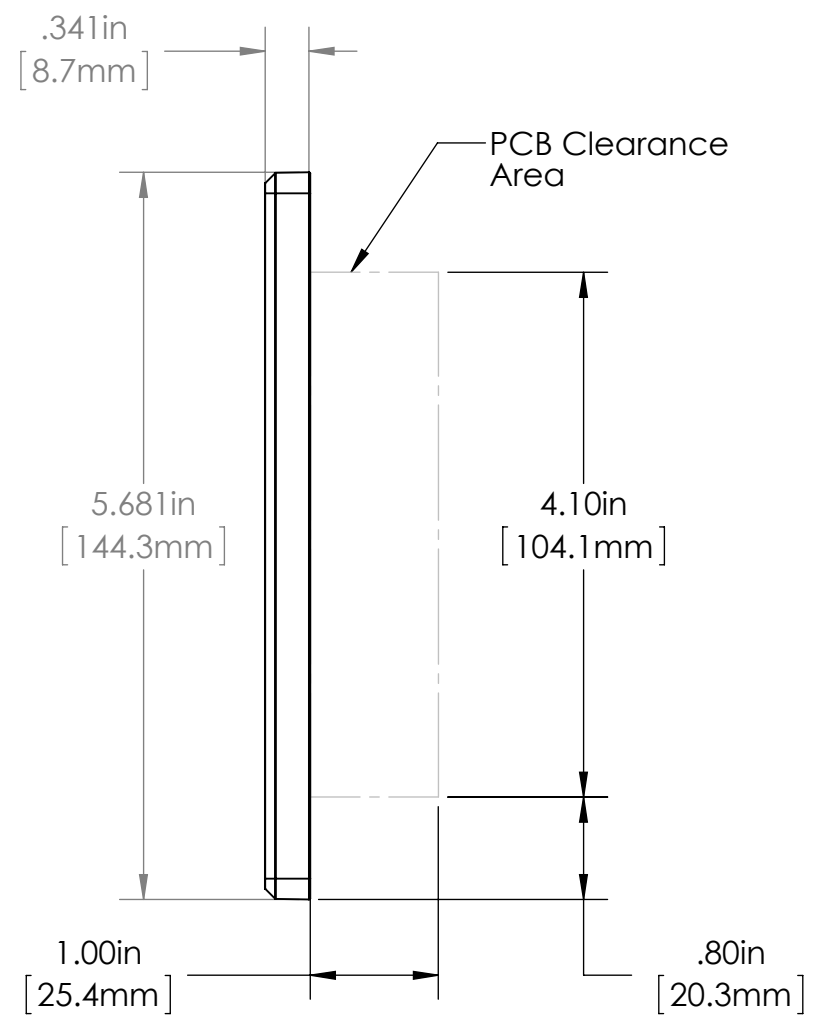
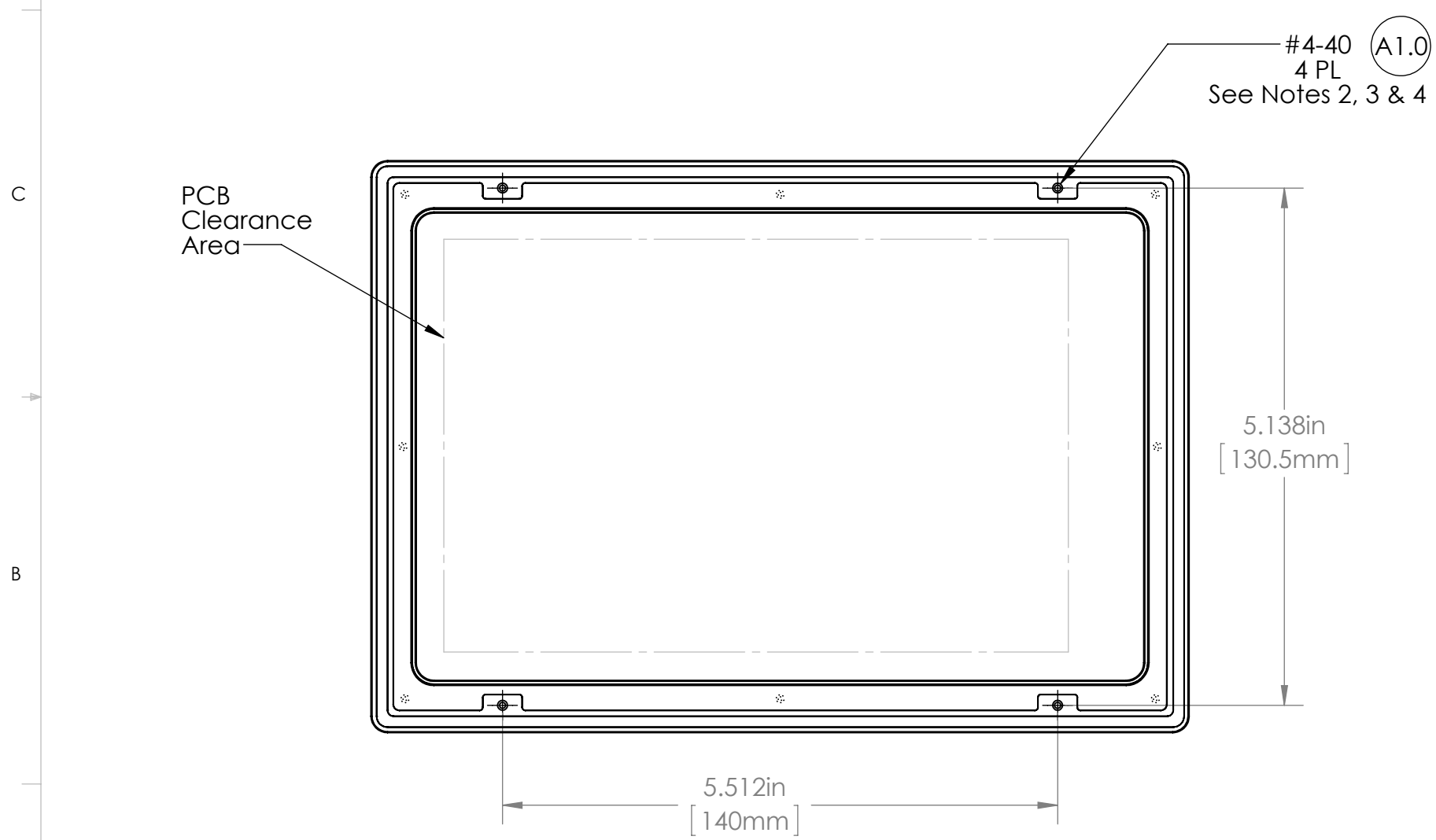

**GENERAL NOTES:**

1. All dimensions in Inches and [Millimeters]
2. Do not use Loctite or similar thread locking material
3. Recommend applied torque of 40 in-oz
4. Recommend using lockwashers with mounting screws

**PROPRIETARY AND CONFIDENTIAL**  
 THE INFORMATION CONTAINED IN THIS DRAWING IS THE SOLE PROPERTY OF **Technologic Systems**. ANY REPRODUCTION IN PART OR AS A WHOLE WITHOUT THE WRITTEN PERMISSION OF **Technologic Systems** IS PROHIBITED.

APPLICATION	DO NOT SCALE DRAWING
NEXT ASSY	USED ON

UNLESS OTHERWISE SPECIFIED:	
DIMENSIONS ARE IN INCHES	
TOLERANCES:	
FRACTIONAL: 1/64	
ANGULAR: MACH ± .25° BEND ± 1°	
x.xxx ± .005	
x.xx ± .010	
x.x ± .020	
INTERPRET GEOMETRIC TOLERANCING PER:	
MATERIAL	None
FINISH	None

NAME	DATE
DRAWN JRK	9/23/16
CHECKED JRK	9/23/16
ENG APPR.	
MFG APPR.	
Q.A.	
COMMENTS:	

**Technologic Systems**

**TITLE:** TS-TPC-7990, Mounting & Clearance

**SIZE:** **B** **DWG. NO.:** 02-7595-5 **A1.0**

**SCALE:** NONE **SHEET 1 OF 1**